

# THE FOX BLOCKS ICF GUIDEBOOK

Insulated Concrete Form  
Technical Guidebook & Training Guide

## CONTENTS OF GUIDEBOOK

### Why Contractors are Choosing Fox Blocks

Fox Blocks Training Programs	3
Fox Block End View Sizing	4
Fox Block Line-Up	5
The True Cost of Fox Blocks	6
Remove Costs on Your ICF Project	7
Fox Block Interlock	8
Fox Blocks Studs	10
Fox Block HV Clip	11

### Fox Blocks Products

Extended 90° Corners	12
The Fox Block T-Block	13
Fox Block Curb Block	14
Fox Buck Continuous Insulation	16
Energy Stick	18

### How-To Section

Fox Blocks Steel Shelf Angle Attachment	20
Fox Blocks Rim Joist Attachment	21
Fox Blocks Shallow Frost/Stem Walls	22
ICF Bracing/Scaffold	23

### Estimating Fox Blocks

Sample Cross Sections	24
Basic Estimating	26
Man Hour Rates	28
The Fox Blocks Estimator PRO 4	29

### Appendix

Technical Performance Data	30
Fox Blocks By The Numbers	31

# FOX BLOCKS TRAINING PROGRAMS

As Fox Blocks expands throughout North America, training courses follow to ensure proper knowledge and techniques are used during installations.

Trainings are tailored to the region and focus on contractors, building officials, Engineers/Architects and/or building supply yards.

After successful completion of installation training and submittal of required paperwork, contractors receive a wallet card. This wallet card provides the necessary proof of training that is sometimes required by building officials.

As contractors gain experience, Fox Blocks issues them higher level wallet cards. This allows us to understand how qualified the contractor is for larger, more complicated Fox Blocks jobs that are looking for installers.

## TRAINING OBJECTIVES

- 1) Understanding ICF
- 2) Estimating your job
- 3) Crew Sizing for your job
- 4) Basic Installation of the Fox Block Line-Up

### INSTALLER LEVELS



**Your Name**  
**PRIMARY INSTALLER**  
 ID# 00000  
 Date Of Issue 03/29/11 Expiration Date 03/29/13

This is to acknowledge that the following individual has completed in class ICF training or has been site verified demonstrating the skills required to successfully install basic Fox Blocks jobs.

**PRIMARY INSTALLER:**  
 Successfully completed one ICF project or completed in class training.



**Your Name**  
**JOURNEYMAN INSTALLER**  
 Cardholder has successfully installed over 1,500 blocks.  
 ID# 00000  
 Date Of Issue 03/29/11 Expiration Date 03/29/13

This is to acknowledge that the following individual has completed in class ICF training or has been site verified demonstrating the skills required to successfully install basic Fox Blocks jobs.

**JOURNEYMAN INSTALLER:**  
 Successfully completed 5 Fox Blocks projects (or 1500+ Block).



**Your Name**  
**MASTER INSTALLER**  
 Cardholder has successfully installed over 4,500 blocks.  
 ID# 00000  
 Date Of Issue 03/29/11 Expiration Date 03/29/13

This is to acknowledge that the following individual has completed in class ICF training or has been site verified demonstrating the skills required to successfully install Fox Blocks jobs.

**MASTER INSTALLER:**  
 Successfully completed 15 Fox Blocks projects (or 4500+ Block).  
*Regional Manager & Dealer will Confirm*



**Your Name**  
**ELITE PREMIER INSTALLER**  
 Cardholder has successfully installed over 9,000 blocks.  
 ID# 00000  
 Date Of Issue 03/29/11 Expiration Date 03/29/13

This is to acknowledge that the following individual has completed in class ICF training or has been site verified demonstrating the skills required to successfully install Fox Blocks jobs.

**ELITE PREMIER INSTALLER:**  
 Successfully completed 30 Fox Blocks projects (or 9000+ Block).  
*Regional Manager & Dealer will Confirm*

# FOX BLOCK END VIEW SIZING

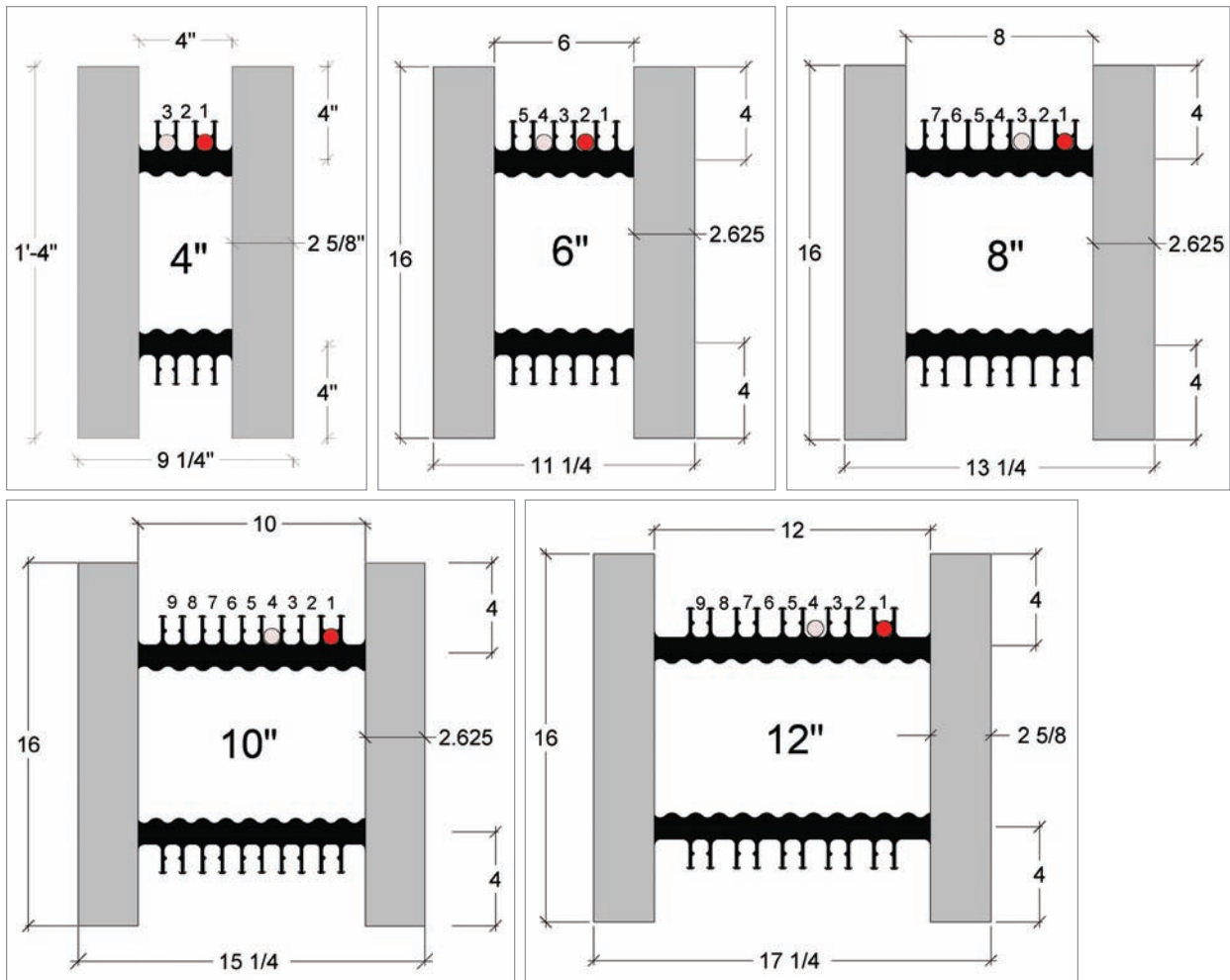

## NOTES:

- 1) Straight Blocks are 48" in length.
- 2) All block have 2 5/8" EPS for consistent R-Value.
- 3) Rebar spacing is consistently 16" o/c and lower truss is 8" o/c from top or bottom of upper truss.
- 4) All block work with each other, example the 4" block will connect to all sizes of block.
- 5) The 4" block is the size of a 2 x 10 and the 6" block is the size of a 2 x 12 which is perfect for wood bucks.
- 6) Rebar notches are designed to lap rebar on top of each other to ensure proper concrete placement.

# THE FOX BLOCK LINE-UP

With advice from leading contractors in the Insulated Concrete Form business, Fox Blocks has created an incredible group of blocks.

## FOX BLOCK LINE-UP INCLUDES:

*(Please note: Fox Blocks are reversible. As an example, each corner block is a left or a right.)*

### A) STRAIGHT BLOCKS

Available in 4", 6", 8", 10" and 12".

### B) STRAIGHT 1/2 BLOCK

Available in 4", 6", 8", 10" and 12".

### C) EXTENDED 90° CORNERS

Available in 4", 6", 8", 10" and 12".

### D) EXTENDED 90° CORNER 1/2 BLOCK

Available in 4", 6", 8", 10" and 12".

### E) 45° CORNER BLOCKS

Available for 4", 6" and 8".

### F) T-BLOCKS

Available in 6" and 8".

### G) CORBEL LEDGE BLOCKS

Available in 6" and 8".

### H) RADIUS BLOCKS

For 5', 6', 7', 8', 9' and 10' radius.  
Only available in the 6" blocks.

### I) TAPER TOP BLOCK

Available in 6" and 8".

### J) CURB BLOCK

Available in 8" Straight and 90°

### K) 4" HIGH EXTENSION

When you need extra height or to help with openings.

### L) ENERGY STICKS

One size fits all.

### M) FOX BUCK

Available in 4", 6", 8", 10" and 12".

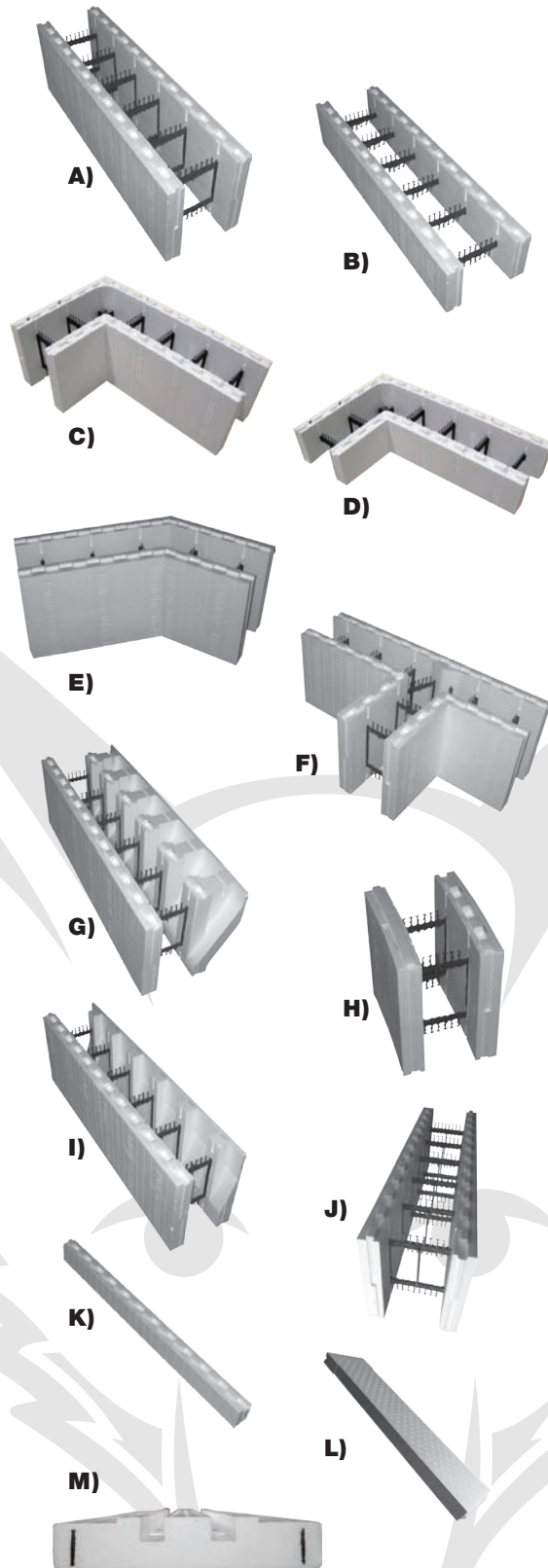

# THE TRUE COST OF FOX BLOCKS

To help understand the cost advantage of using Fox Blocks Industrial Strength Insulated Concrete Forms (ICF), consider the following key points:

## THREE KEY AREAS GIVE YOU THE TRUE, ACCURATE COST OF THE ICF YOU CHOOSE:

### 1) ICF BLOCK COST

Most ICF fall within \$0.10 per square foot of each other in block cost, which is a minor portion of the overall cost of the wall construction. You must get "All-In" landed ICF System cost to accurately compare.

### 2) ANCILLARY PRODUCT COST

Add in all ancillary product costs that are not in the block quote. A common example is most ICF require internal truss wire to give needed strength to the system. Know what's required within system install guidelines to produce a straight wall. See other side for examples that will save you time & money on your next job.

### 3) MAN HOUR RATE TO INSTALL

Eliminating tasks will shave hours/days off the project. Installation labor is the largest portion of overall ICF cost. Seek full disclosure on man hour rates to install the ICF system you are considering. Listening to experienced installing contractors and gaining an understanding of the attributes of ICF products, can make the difference between a streamlined, profitable job and one that is not.

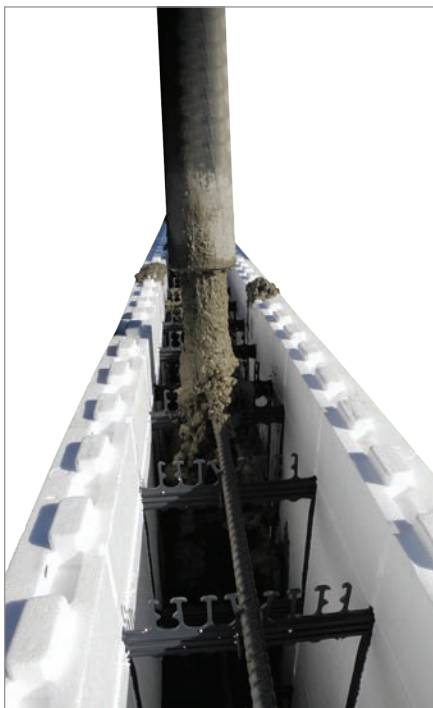

## AT FOX BLOCKS:

### EXPERIENCE

Airlite Plastics Co., the parent company of Fox Blocks, manufactured many different brands of ICF over the past 15+ years. Much experience was gained while producing over 45 million square feet of ICF. Designed, engineered and delivered to your local market.

### COMPETENCE

Airlite Plastics controls all aspects of development and production = "Industry Leading Products".

### COMMON SENSE

We went to the field and asked the professionals what they needed to be effective and efficient. After listening to them, we produced an Industrial Strength ICF called Fox Block!

### STABILITY

Since 1946, the family run Airlite Plastics business has grown and provided high quality, proven products over the decades. We have, and will continue, to provide the highest quality products to the construction industry for years to come.

# REMOVE COSTS ON YOUR ICF PROJECT

## TWO PROVEN AREAS TO REMOVE COST:

### 1) CORNERS

**PROBLEM:** Historically, Corner Blocks have proven to be very difficult for installing contractors to hold the corner positioning or actually holding concrete during the consolidation process. Contractors have resorted to inserting internal ties, external strapping and bracing to gain needed strength. This adds cost in additional materials and man-hour rates.



Some competitive ICF strap corners with lumber for strength during concrete placement.

**SOLUTION:** Our engineering staff at Fox Blocks developed more length to the corners and introduced the heaviest cross tie corner bracket on the market. Adding these features to our large/strong interlock, stopped rotation or movement within the blocks during the pour and added needed burst strength. Having this bracket and no less than two ties from each corner in all 45° and 90° block eliminates the need for additional strapping or internal ties.

**RESULT:** Confidence to the installing contractor, lower man hour rates, and lower material costs proven by over 8 years of successful projects. Utilizing our Fox Blocks “next generation” corner block design will save you money through time and material reductions.

**COST:** The Fox Blocks corners cost the same per square foot as the Fox straight block. Cost will appear higher than our competitors because our corners are 16" or more in length. In many cases, our corners are actually lower in cost per square foot and at the same time save you even more in time and materials.



The Fox Blocks extended 90° corner block showing it's stand alone strength during concrete placement.



The Fox Blocks extended 90° corner block with an extra tie on each end for strength.

### 2) TRUSS WIRE (FORM LOCK, BLOCK LOCK)

**PROBLEM:** Some ICF interlocks and slender plastic webs have caused the need of internal truss wire to aid in producing adequate strength to add rigidity to produce a straight wall.

**SOLUTION:** Two very simple Fox Blocks innovations cured this problem: 1) A bold and reversible interlock was created to help hold the wall true. 2) A full height internal tie was designed to use solid stacking strength to hold the wall from settling or racking.

**RESULT:** A wall that, through design, eliminates the need for truss wire.

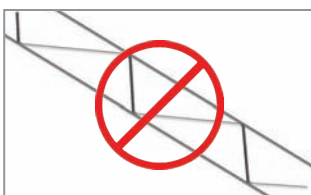

#### USING FOX BLOCKS ELIMINATES THE NEED FOR TRUSS WIRE

Truss wire costs over \$0.50 per lineal foot and is called for at bottom of wall and every 4 or 5 rows of block. Actual cost = Over \$0.14 per sq ft in materials and at least \$0.04 per sq ft labor for a total of \$0.18 or more per sq ft cost. This is equivalent to \$0.40 per block

# THE FOX BLOCK INTERLOCK

## THE OLD

For the past 20+ years, the interlock of most ICF in the industry have been designed to be within 1/2" to 1" of the desired building dimension. Most contractors have been trained that it is acceptable to be this far off the desired dimension.



Shows the large 2" long projections and recesses and the full height 1 1/2" wide tie

## THE NEW

When the Fox Blocks interlock was designed, our engineering staff made the choice not to focus on being within 1/2" to 1" from the building dimension, but to give the strongest interlock possible. To do this, they turned the projections and recesses of the interlock parallel to the block itself and for simplicity/strength made them 1" wide and 2" long.

***Walls should be square and built to the building dimensions. For this reason, Fox Blocks recommends stacking seams when needed.***



Here is a job, post concrete, that has been constructed exactly to the building dimension by properly stacking seams.

## BENEFITS OF THE LARGE INTERLOCK:

- Minimized movement during concrete placement
- No adhesive required due to tightness of interlock
- Eliminates the need for truss wire within the wall
- The full height ties are always on top or 4" apart of each other

*Review next page to see the proper procedure for stacking seams.*



## THE NEW TRAINING:

### ROW ONE:

Simply start from each corner to a point within the wall. Cut one of the blocks to fit perfectly. The cut does NOT need to be on the cut lines. Measure the cut block and mark its measurement to the side of that block large enough for everyone to see.

### ROW TWO:

Start at the corners again placing the corner block the opposite direction from row one to give an overlap with the block. When you reach the cut block on row one, cut the block above it to line up exactly. Again the cut does not need to be on the cut line. Measure the cut block and mark its measurement to the side of that block large enough for everyone to see.

### ROW THREE:

*(five, seven, nine, etc)*

Should be exactly the same as row one.

### ROW FOUR:

*(six, eight, ten, etc)*

Should be exactly the same as row two.

### PRIOR TO CONCRETE:

Simply connect the vertical seam that you created, at the one point in the wall, with strapping, or plywood, on both sides of each block. Use one 12" to 24" long strap, 3" to 6" wide, made out of 1 x wood boards or plywood sheathing attached with one screw in each tie on each side of seam.

### RESULTS:

We have found that the man hour rate will drop using this method because the crew spends less time thinking how they can get closer to the building dimension and more time actually being productive.



**WRONG**



**CORRECT**

We have found it to be a waste of time and energy to attempt to offset or stagger the block, at the meeting point, as in the photo to the left. By creating a vertical stacked seam you will be more accurate with the job dimensions and will increase your profit by gaining efficiency with your crew.

### BUILDING MULTIPLE LEVELS WITH DIFFERENT SIZED BLOCK

All sizes of Fox Blocks ICF fit well on top of each other for any type of configuration with little or no modifications needed. This is simple math. Fox Blocks ICF are reversible with 2" projections and recesses, which means you will work with a 4" offset. For this reason, the 4", 8" and 12" block all work well together, as they are all divisible by 4". Using the same math, the 6" block attaches to all sizes of Fox Blocks with a 2" difference in tie alignment. This is not a concern as this joint line will usually happen at a floor diaphragm.

### 6" CORNER BLOCK ON TOP OF 8", 10" OR 12" CORNER BLOCK:

The 6" corner works well on top of the 8", 10" or 12" corner blocks when going around an outside corner. For inside corners, simply remove the projections off the corner block and continue building. You may need to create a stacked seam on one or both sides of the inside corner, at which time, we recommend moving the stacked seams for each wall closer to that inside corner.

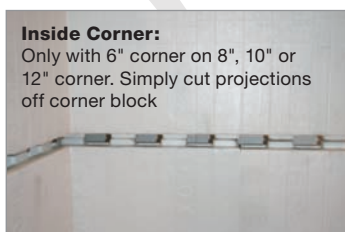

**Inside Corner:**  
Only with 6" corner on 8", 10" or 12" corner. Simply cut projections off corner block

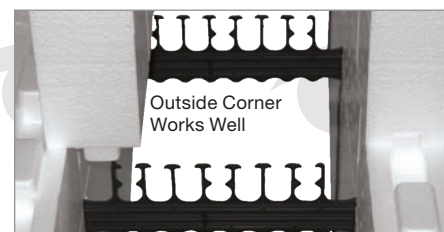

**Outside Corner Works Well**

6" 90° corner block on top of 8", 10" or 12" 90° corner block

# FOX BLOCK STUDS

You are a sheetrock, residential wood frame, commercial steel stud or siding contractor that has been trained, and are efficient with, a continuous 1 1/2" wide attachment surface @ 16" on center.

Our team at Fox Blocks agrees with this tradition and created our ICF with the same continuous 1 1/2" wide attachment surface, but increased it to 8" on center.

Just think, when attaching sheet rock or siding to Fox Blocks Insulated Concrete Forms, you can use the same training you previously used and understand.

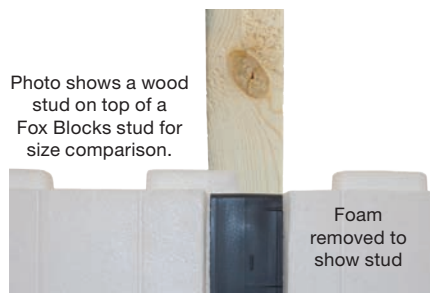

Photo shows a wood stud on top of a Fox Blocks stud for size comparison.

## FOX BLOCKS ICF

- A full 1 1/2" wide
- 8" o/c to achieve industry standard 16" o/c's
- No gap every 16" vertically due to ties touching
- Minimal settling due to ties touching
- Not effected by moisture, will not rot
- Will not move due to temperature and humidity changes
- Eliminates most sheetrock / drywall repairs
- Made of non-organic materials



## ACTUAL FOX BLOCKS WALL

- Studs clearly marked @ 8" o/c
- Studs are in contact with each other vertically
- Studs buried into foam 5/8" for stucco application and thermal performance

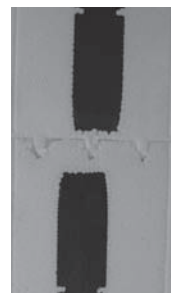

## OTHER ICF

- As narrow as 1" wide
- As much as 1 3/4" gap every 16" vertically due to ties not touching
- Settling due to ties not touching



## WOOD STUDS TODAY

- Much larger grain than 15 years ago
- More knots and checks than 15 years ago
- Reject screws more than 15 years ago
- Prone to movement through seasons
- Prone to rot when sealed with moisture
- Prone to sheetrock / drywall repairs
- Food for insects

## FOX BLOCKS STUDS

- Recycled polypropylene
- LEED credits\*
- 120 lbs+ pullout / shear strength with screws\*\*
- Use screws that are the thickness of material plus 1 1/8" + in length.
- If the screws that you are using do not hold, try the next size longer. The tip of the screw must pass completely through the tie to achieve full strength.

\* See LEED documents at: <http://www.foxblocks.com/Resource-Center/Technical-Resources/LEED-and-Environmental-Documents.aspx>

\*\* See testing results at: <http://www.foxblocks.com/Resource-Center/Technical-Resources/Testing-Reports.aspx>

# THE FOX BLOCK HV CLIP

Contractors have asked for a wire clip to secure their Fox Block jobs together, so the team at Fox Blocks went to work designing one. Fox Block ties are engineered to be perfectly balanced, spaced at 8" o/c Horizontally and Vertically, and to give flat walls post concrete. This allowed us to put all of our design into one wire clip, which helps everyone with only one sku.

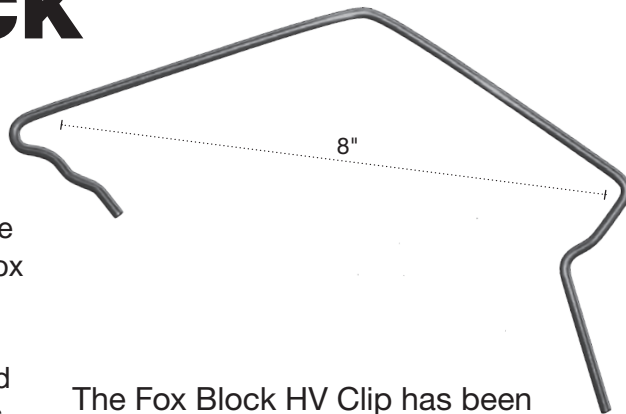

The Fox Block HV Clip has been engineered with eight bends, allowing one clip to work horizontally or vertically.

## HV CLIP PLACEMENT:

### BOTTOM ROW:

Horizontally across every joint **1**

### CORNERS:

Horizontally across each joint **1**  
Vertically on first ties **2**

### TOP ROW:

Horizontally across every joint **1**  
Vertically on second tie from every joint **3**

### OPENINGS:

Vertically up wall on each side of openings

### BUDGET:

One box for every 150 block ordered  
One box = 250 Fox Block HV Clips

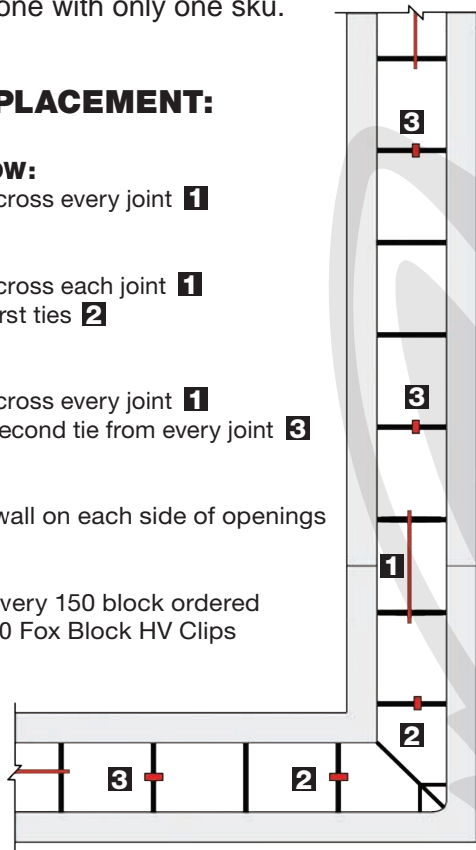

## FOX BLOCK HV CLIP POSITIONS



Vertical Clips in Place



Horizontal Clips in Place

Note: You can skew the HV Clip a notch or two for an even tighter fit, if needed.

## FOX BLOCK HV CLIP BEING USED ON JOBS

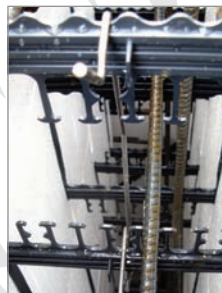

Vertical & Horizontal Clips in place close to corner



Showing HV Clips holding down a top row that has been cut down to +/- 8" in height

Using the Fox Block HV clip completely eliminates the need for truss wire on your jobs. The result is that for about 1/2 the cost of the truss wire, you will get a stronger and straighter job.



Product Label



# EXTENDED 90° CORNER

Fox Blocks engineered the 90° corner to hold concrete without the need for extra strapping or external bracing.

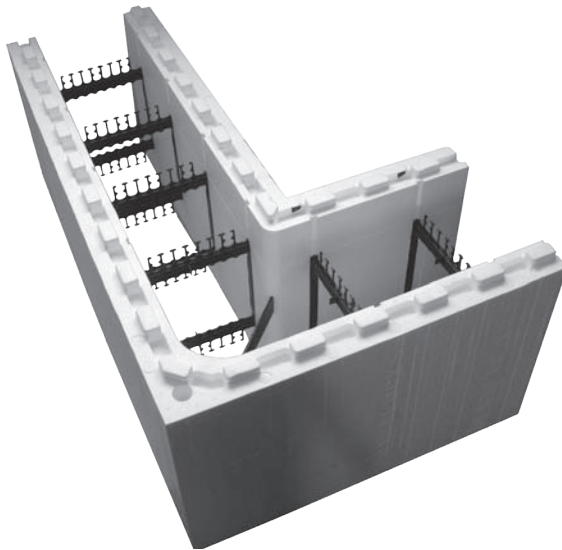

## FOX BLOCKS EXTENDED CORNER FEATURES:

- 1) All blocks have Ties\* at 8" o/c and are available in 4", 6", 8", 10" and 12" cavities.
 

*\* Ties are the black recycled polypropylene members that give the block strength and provide rebar positioning.*
- 2) Like all Fox Blocks, corner blocks are reversible so when you ask for a corner you will get the correct one every time. Each corner is left or right automatically!
- 3) Foam thickness is 2.625" on all forms.
- 4) Tie allows rebar lap splices to lay on top of each other for good flowability during concrete placement.
- 5) Ties are clearly marked on EPS for attachments.
- 6) Tie flanges are 1.5" wide and full height for ease of attachment.
- 7) Ties touch vertically when stacked eliminating form settlement.
- 8) Each corner has a 1" hole strategically placed to allow the ICF contractor the option of inserting a full height 3/4" PVC conduit to tie all courses together for extra form support.

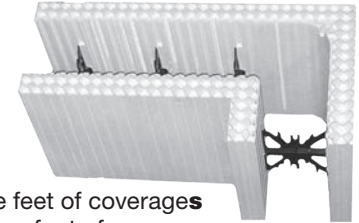

### OTHER ICF 90s

- 5 to 5.33 total square feet of coverages
- More costly per square foot of coverage
- 16" shorter than Fox Blocks
- Only 4 ties
- Only one tie on short end
- More movement during concrete

### FOX BLOCKS 90s

- 7.56 total square feet of coverage
- Less costly per square foot of coverage
- 16" longer than other ICF
- 6 ties
- Two ties on short end
- Less movement during concrete

Being 16" longer than other ICF, allows you to eliminate one full straight block for every three Fox Blocks corners used. This also saves you money!

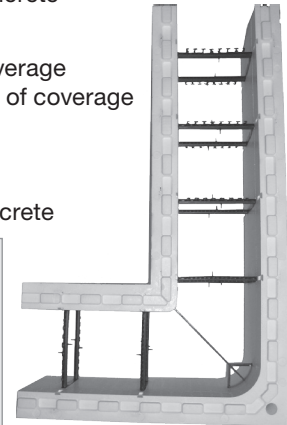

**Radius** on the inside face of the Fox Blocks Corners are:

4", 6" and 8" Blocks = **3"** 10" and 12" Blocks = **8 1/2"**

Additional EPS was added to the 10" and 12" Corner Blocks to give additional strength for the longer distance from corner to 1st tie.



Every Fox Blocks corner has a large 100 sq. inch fastening zone in the corner.

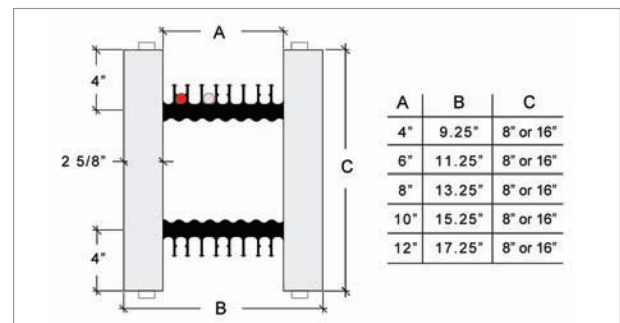
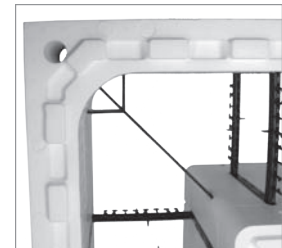

Fox Blocks 90° Extended Corner Size Chart

### OUTSIDE DIMENSIONS ARE:

- 4" Corner = 38" x 22"
- 6" Corner = 40" x 24"
- 8" Corner = 42" x 26"
- 10" Corner = 42" x 26"
- 12" Corner = 46" x 30"

# THE FOX BLOCK T-BLOCK

Sure you can build T walls with a couple of straight block and some tie wire, but if you want to lower your Man Hour Rate, you need the **Fox Blocks T-Block**.

When contractors said they needed a T-Block, Fox Blocks delivered one that is easy to use and incredibly strong.

## FOX BLOCK T-BLOCK FEATURES:

- 1) The T-Blocks are available in 6" and 8" concrete cores.
- 2) Six T-Blocks per bundle (3 short and 3 long)
- 3) Two ties\* are used at the intersection of the "T" to give maximum strength and attachment. These ties are placed in such a way as to allow proper rebar placement and ultimate form strength.  
*\* Ties are the black recycled polypropylene members that give the block strength and provide rebar positioning.*
- 4) Like all Fox Blocks, blocks are reversible which gives you double the options with just one block. You can choose to have the T section on the right or left of center simply by flipping the block over.
- 5) Foam thickness is 2.625" on all blocks.
- 6) Ties allow proper rebar lap splices, for maximum flowability during concrete placement and consolidation.
- 7) Ties are clearly marked in EPS for attachments.
- 8) Tie flanges are 1.5" wide and full height for ease of attachment.
- 9) Ties touch vertically when stacked eliminating form settlement.
- 10) The T-Block will give you 8" of overlap most directions.

## 8" T-BLOCK INSTALLATION

The unique manufacturing challenges were overcome for the 8" T-Block by establishing a 4" offset. This off-set results in rows of ties staggered by 4" if placed with factory ends against each other. The easy fix to properly line up ties is to install the T-Block and create a stacked joint at the butt end of the long T leg. Strap stack joint prior to concrete placement.

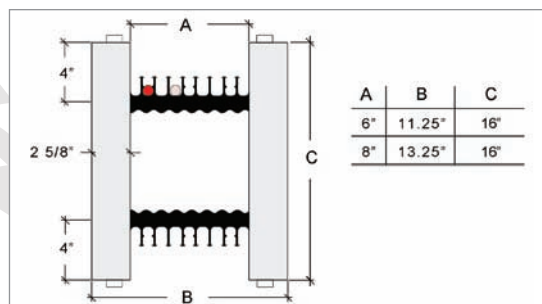
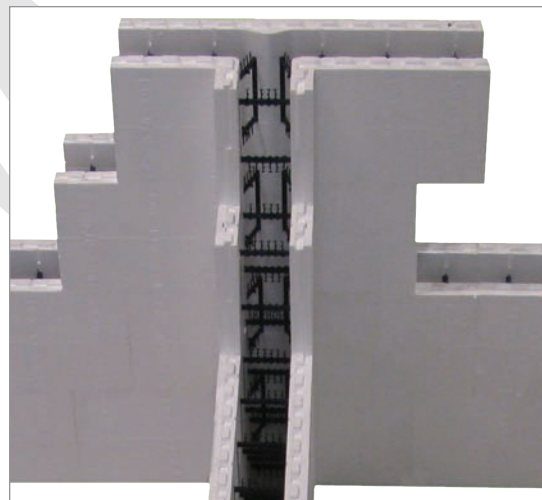
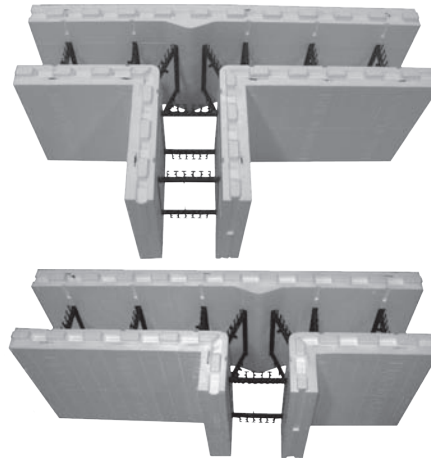

### OUTSIDE DIMENSIONS ARE:

- 6" T - Block Short = 44" x 4.375"
- 6" T - Block Long = 44" x 12.375"
- 8" T - Block Short = 44" x 4.75"
- 8" T - Block Long = 44" x 8.75"

# THE FOX CURB BLOCK

There has always been a need for a block that can create a ledge to support floor systems within the wall without limiting you to course heights. The Fox Blocks team solved this by adding an extra attachment point within the tie. This patent pending solution will allow you to form a curb with the block to support whatever you need to support.

## USING THE CURB BLOCK:

### 1) INSTALLATION

See following page for proper steps using the curb block

### 2) SHAPES AVAILABLE WITH THE CURB BLOCK:

At this time, 8" Straight and 8" 90° corner blocks are available with the curb block

### 3) RANGE OF USE:

The Curb Block can be cut down as low as 11" from the top of the block. You can also cut up to as much as 11" from the bottom of the block to use when wrapping around concrete slabs. See page two for an example of this.

### 4) ESTIMATING:

Straight blocks = 4'-0" long.

Formula: (Total linear footage of wall - total linear footage taken up by 90° corners) / 4 = Number of straight curb blocks

90° corner blocks = 5'-4" each.

Formula: Number of 90° turns = Number of 90° corner blocks

### 5) IDENTIFICATION:

The Curb Block has been designed with a green tie for easy identification. By producing the ties in green, supply yards will be able to identify and send you the proper block. This will also ensure your crew will not use it up in the wall at the wrong time.

### 6) BUNDLE SIZES:

Straight block = 12 per bundle

90° corner block = 6 per bundle

### 7) EXCESS BLOCK?:

If you end up with extra Curb Block on site you can save for next job or simply use them up within the walls you are building. The shape and size of the Curb Block is identical to the normal straight and 90° corner blocks.

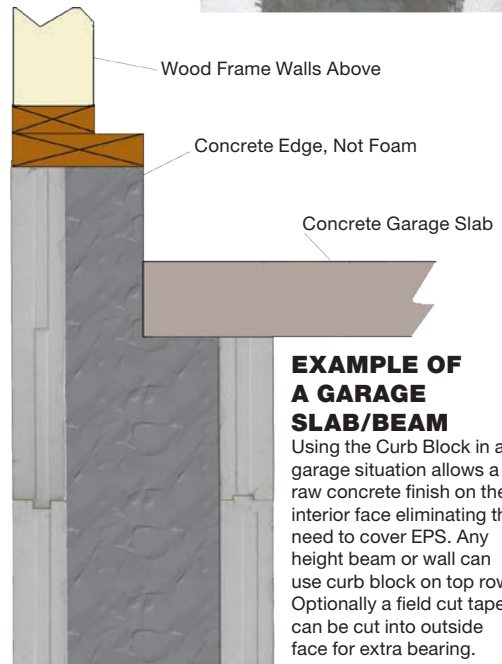
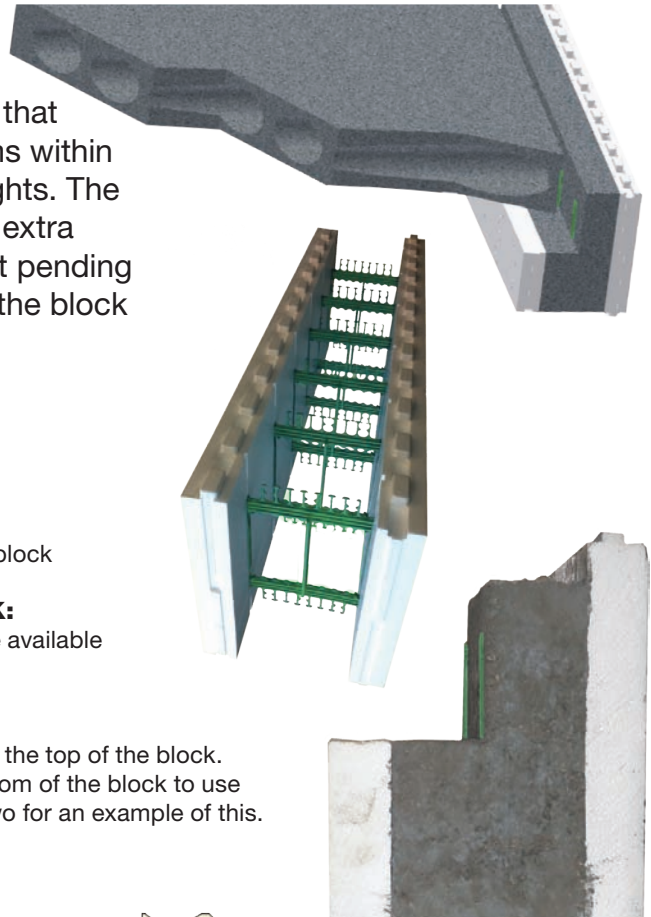

### EXAMPLE OF A GARAGE SLAB/BEAM

Using the Curb Block in a garage situation allows a raw concrete finish on the interior face eliminating the need to cover EPS. Any height beam or wall can use curb block on top row. Optionally a field cut taper can be cut into outside face for extra bearing.

# CURB BLOCK INSTALLATION & USES

## INSTALLATION STEPS:

### STEP 1

Separate Curb Block bundles and set aside until needed. You can identify the Curb Block by the green ties.

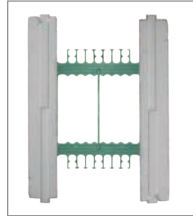

### STEP 2

Decide where you need the concrete shelf elevation to land and either mark and rip-cut the block with a circular saw or set a fence on a table saw and make your cut. Finish cut by cutting the tie with a handsaw.

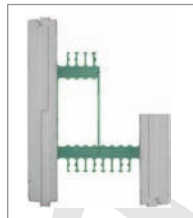

### STEP 3

Attach forming to the Curb Block inner ties. Simply screw two #8 coarse threaded screws to each tie to withstand concrete pressure. Fox Blocks recommends the use of 1/2" or thicker plywood or equivalent.

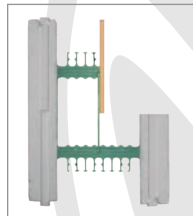

### STEP 4

Place concrete as normal. For best results, Fox Blocks recommends properly consolidating entire wall including Curb Block.



### STEP 5

After sufficient curing, remove form boards. You now have a solid concrete ledge for supporting what you need supported.



### STEP 7

If you need extra support, a taper can be cut prior to concrete placement to allow for up to a 6 1/4" ledge.



## CURB BLOCK USES:

- Hollowcore
- Precast
- Dimensional Wood Floors
- Engineered Wood Floors
- Truss Floors
- Brick
- Garage Slabs
- Creating Recesses (See Below)
- Hambro Floors
- Pan Deck

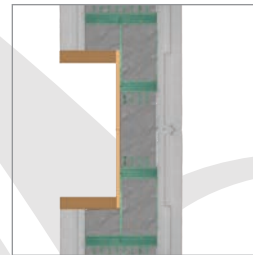

### EXAMPLE OF A WALL RECESS

This type of application will be treated as an opening in the wall and will require extra reinforcing within the concrete (rebar). The Curb Block will allow openings up to 22" in height using two blocks.



### WOOD FLOORS

For the real life example above, we cut off 6" from the left side, turned the cut-off over and connected to the right side creating a 12" curb. This works well with wood floors by giving you ultra strength without any concerns of moisture in the future.

# FOX BUCK CONTINUOUS INSULATION

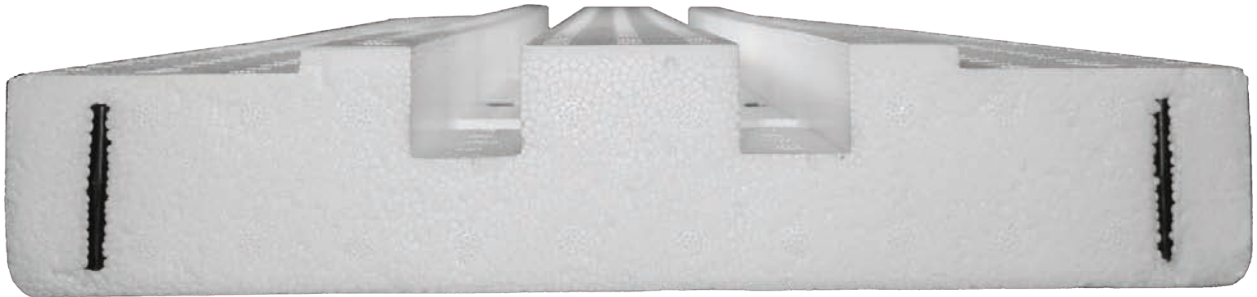

Contractors, design professionals, and building owners have been asking to address the ICF buck issues for years. The Fox Blocks team now has the answer: A fully integrated, continuous insulation window and door buck for commercial and residential ICF wall openings.

Dual full length 1" x 1" grooves to create solid concrete barriers against drafts and moisture penetration

Notches ensure proper Fox Buck and Fox Block alignment

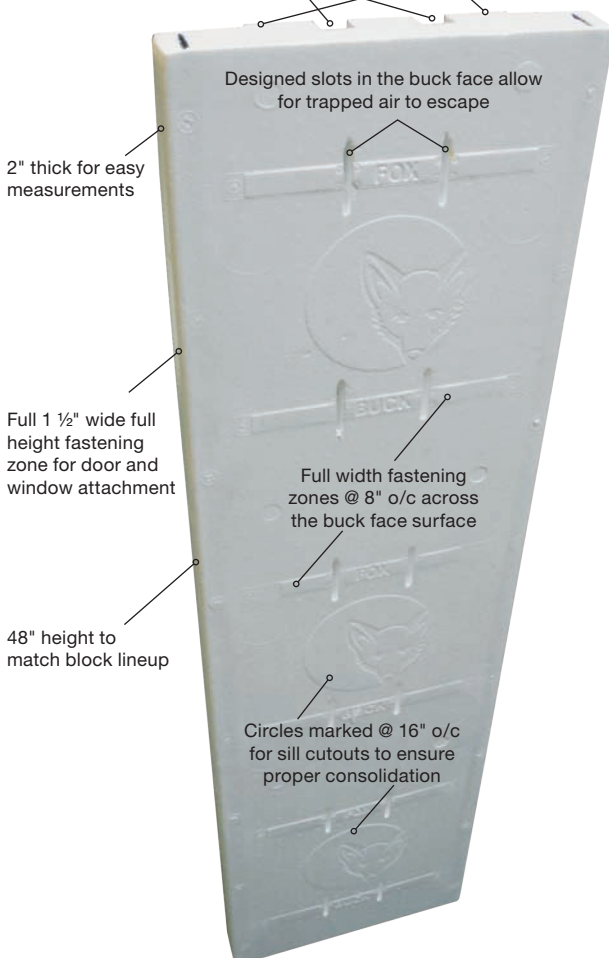

## FOX BUCK NUMBERS

Available Sizes	4"	6"	8"	10"	12"
Total Width	9.25"	11.25"	13.25"	15.25"	17.25"
Total Length	48"	48"	48"	48"	48"
Bundle Quantity	12	12	12	12	12
Bundle Weight	29 lbs	33 lbs	38 lbs	42 lbs	46 lbs



Photo above reveals consolidated concrete barriers created within the Fox Buck

The 1" x 1" notches create a dual barrier against drafts or moisture penetration. When installed properly, the concrete barrier protection is continuous around the entire opening. These barriers also anchor the Fox Buck to the wall with enough strength to hold in most weather\* conditions

\* Contact Fox Blocks for high wind anchoring recommendations.



The Fox Buck was designed to be compatible with the Fox Energy Stick, maintaining the continuous concrete barriers.



# INSTALLING THE FOX BUCK

## INSTALLATION STEPS:

### STEP 1

- a) Build wall as normal with opening 4" larger than rough opening.
- b) Ensure all opening rebar is properly placed and secured.
- c) Double check opening measurements.



Temporary support can be attached to Fox Buck fastening zones.



### STEP 2

- a) Cut sides to length and notch each end 1" as in photo.
- b) Place Fox Buck sides into place and hold with tape.

*Option: Spray foam can be used to completely seal buck to block*

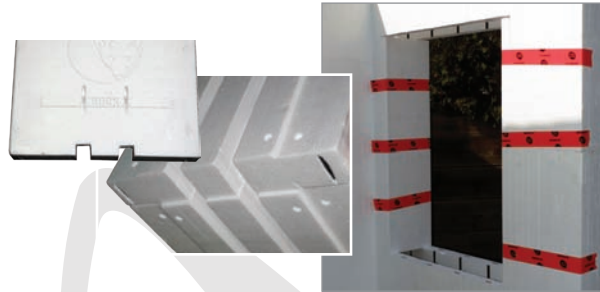

### STEP 3

- a) Cut and place top and bottom Fox Bucks  
*Option: Spray foam can be used to completely seal buck to block*
- b) Penetrate all slots with a nail or screw to ensure entrapped air can escape during concrete placement.

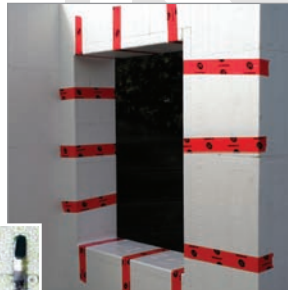

### STEP 5

Brace inside opening to hold square during concrete placement.



### STEP 4

Cut and remove all circles in sill. This will ensure proper concrete consolidation during concrete placement.

#### Notes:

*It is preferred to have these circles cut out prior to placing the Fox Buck sill in place. This will eliminate any foam cutouts accidentally falling into wall cavity.*

*Holes can be cut square to allow maximum hole size for concrete placement.*



### STEP 6

When openings are close to a corner, strapping is required to hold corner in place during concrete placement.



# THE FOX BLOCKS ENERGY STICK

How do you improve an Insulated Concrete Form wall that already out-performs most wall systems in all climates? You move the concrete mass toward the living side of the wall. This unbalanced R-value will allow the mass to be closer to the living temperature of the conditioned space, allowing for a more comfortable building.

The Fox Blocks design team had two goals: 1) Move the mass away from the harsh temperatures and 2) Increase R-value. Each Energy Stick is 8" wide, 32" tall, 2" thick and profiled to fit within all Fox Blocks. The Energy Stick is used to ensure an R-8 boost to the already high R-Value of Fox Blocks.



## SIZING AND ACTUAL R-VALUE

- 6" Block + 1 Energy Stick (R-30+\*) = 4" Concrete
- 8" Block + 1 Energy Stick (R-30+\*) = 6" Concrete
- 10" Block + 1 Energy Stick (R-30+\*) = 8" Concrete
- 10" Block + 2 Energy Sticks (R-39+\*) = 6" Concrete
- 12" Block + 1 Energy Stick (R-30+\*) = 10" Concrete
- 12" Block + 2 Energy Sticks (R-39+\*) = 8" Concrete
- 12" Block + 3 Energy Sticks (R-48+\*) = 6" Concrete

*\* This represents the overall average wall R-value. As an example in wood frame construction a wall with R-19 batt insulation will have an overall average wall R-value of less than R-16 due to thermal bridging.*

## USING THE ENERGY STICK:

### 1) INSTALLATION:

Simply insert the patent pending Energy Sticks between the plastic ties and to the outside face of wall after every two rows of blocks have been placed.

### 2) CORNER BLOCKS:

Fox Block corners are naturally thicker eliminating the need to insert Energy Sticks from the corner tie on. From the last straight tie to the corner tie you will need to wedge the Energy stick in place. A spot of expanding foam will also help to secure the Energy Stick from movement.

### 3) OPENINGS/STACKED SEAMS:

Simply cut the Energy Stick to fit in locations that are narrower than 8". When larger than 8" use expanding foam to hold cut Energy Sticks.

### 4) RANGE OF USE:

The Energy Stick will fit all Fox Blocks.

### 5) ESTIMATING:

3 Energy Sticks for every block ordered.  
One box = 36 Energy Sticks  
One box of Energy Sticks will fill 12 blocks

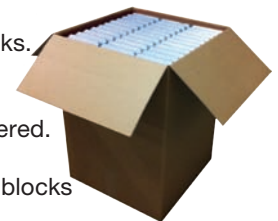

### 6) MAN HOURS:

Allow 4 minutes per box when inserting for the first time (= 950 square feet of wall per hour or .001 man hours per square foot)

### 7) BUNDLE SIZES:

Each box of 36 Energy Sticks = approximately 24" x 24" x 33"

# ENERGY STICK FACTS

## BASE

The bottom of each Energy Stick has been shaped to insert into the top of the previous Energy Stick. The projection is 1/2", which is the same height as the projections on the block. This way, if the projection is left on the bottom of row one, the Energy stick will rest on the footing or slab.

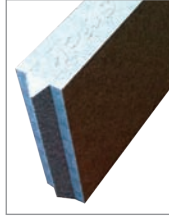

## TOP

The top of each Energy Stick has a recess to accept the bottom of the next Energy Stick. This eliminates movement during concrete placement.

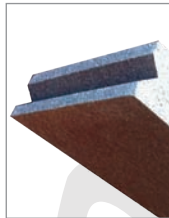

## CONNECTION

The top of every Energy Stick has been designed to fit snug between the ties. The lower 18" has been designed to slide into the block loosely to increase production and then guide itself to connect to the top of the previous Energy Stick.



## SHOULDER

Every Energy Stick has a specially designed shoulder as a stop to ensure every Energy Stick locks into the proper location.



## FOX 1440

The Energy Sticks have been designed to work well in the solid Fox Blocks line as well as the 1440 line.



## R-VALUE

Each Energy Stick layer will add R-8 to the wall. You can insert the energy stick on one or two faces to achieve the R-value desired. As an example, you could add three Energy Stick layers into the 12" block giving as much as R- 45+ with 6" of concrete!



## ADDED BONUS

Fastening point stays consistent with standard blocks. No need for long screws for any attachments!



**ENERGY STICKS IN USE** *Patent Pending*  
Energy Sticks have been field tested. The example above shows a wall that was 9 rows high, which meant the top row used Energy Sticks that were cut in 1/2. Energy Sticks are marked with a cut line for jobs that have an odd number of rows.



# FOX BLOCKS STEEL SHELF ANGLE ATTACHMENT

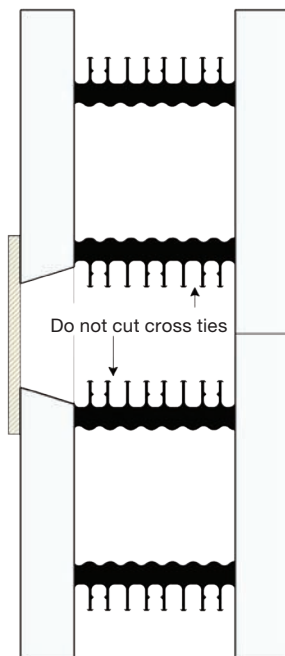

Rip cut blocks on table saw.

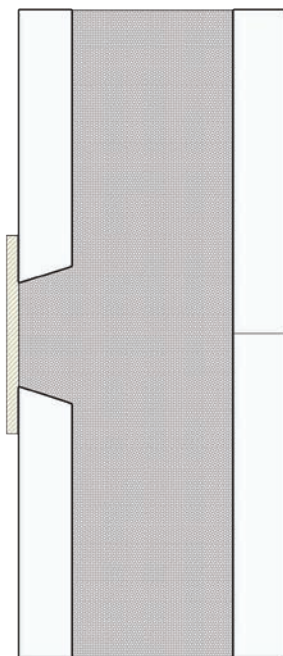

Use form plywood to cover. Common 2 1/2" deck screws work well into the 1 1/2" wide 8" o/c ties.

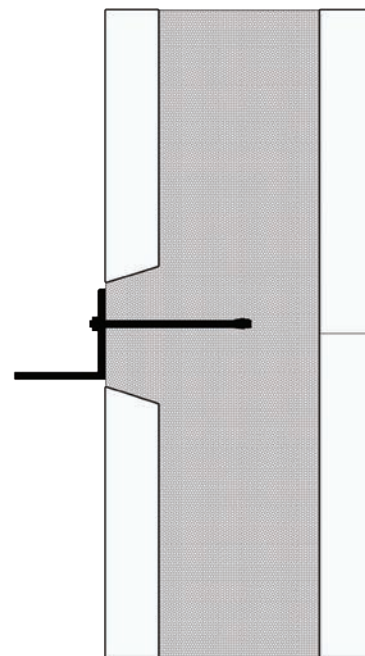

Post concrete remove form plywood and you have termite protection or solid concrete to attach steel angle etc.

Each section marked 'FOX BLOCKS' consists of a 1.5" wide continuous fastening zone buried 5/8" beneath the EPS foam.

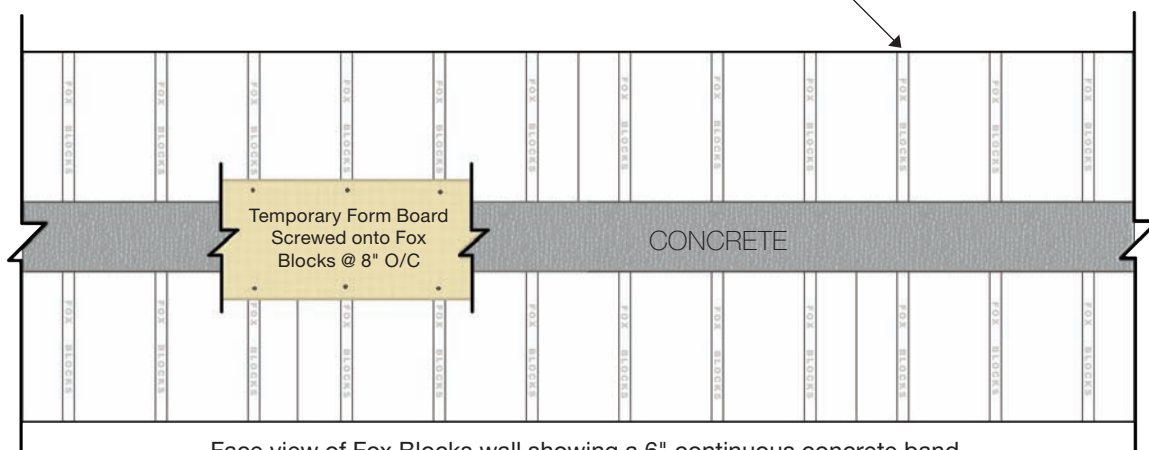

Face view of Fox Blocks wall showing a 6" continuous concrete band

The Fox Blocks design has consistent measurements due to the cross tie locations and full height ties. This will help when laying out a job that requires continuous bands of concrete.

# FOX BLOCKS RIM JOIST ATTACHMENT

There are several ways to attach a floor diaphragm to a Fox Block wall. The most customary has been to simply use common anchor bolts. See bottom for several other options.

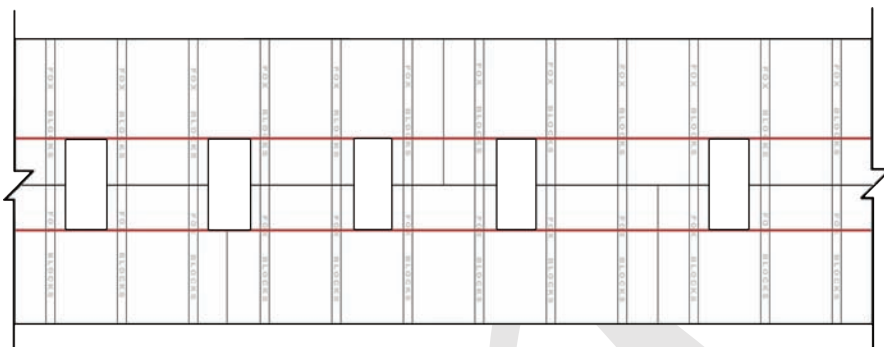

## STEPS FOR RIM JOIST ATTACHMENT:

- 1) Build wall to within one row above rim joist location
- 2) Mark out top and bottom of rim joist location
- 3) Mark out o/c locations for anchor bolts
- 4) Cut out 4" x height of rim joist. Angle top cut up into block to allow air to escape during concrete placement.

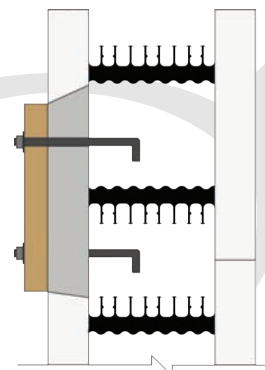
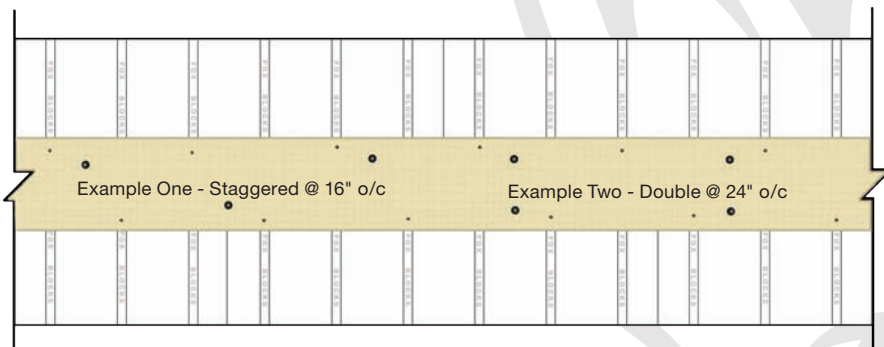

End view of completed Rim Joist attachment

- 5) Place rim joist and attach to Fox Block ties with 3" deck screws
- 6) Mark out anchor bolt locations and drill holes
- 7) Reach inside the Fox Block wall and insert the anchor bolt through the hole you drilled
- 8) Place washer and nut onto anchor bolt. You are now ready for concrete.

## OTHER OPTIONS INCLUDE:

- A) Simpson StrongTie ICF Ledger Connector: <http://www.strongtie.com/products/connectors/icfv1.asp>
- B) Fox Block corbel ledge: <http://www.foxblocks.com/Resource-Center>

# FOX BLOCKS SHALLOW FROST/STEM WALLS

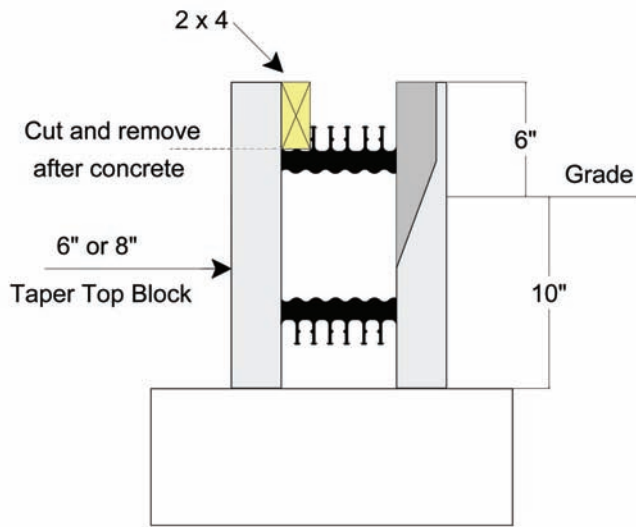

One row of Fox Blocks.  
Fox Blocks is designed to accept a 2 x 4 resting on top of the tie.  
Attach with screws through face of tie.

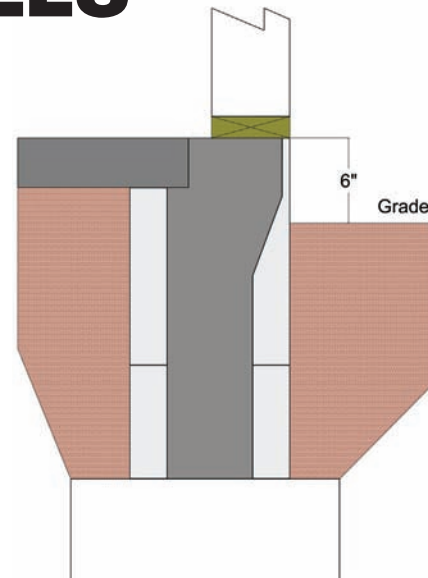

After concrete placement, cut block and remove 2 x 4 to create a shelf for slab to rest on.

Footings and reinforcing to meet local building codes.

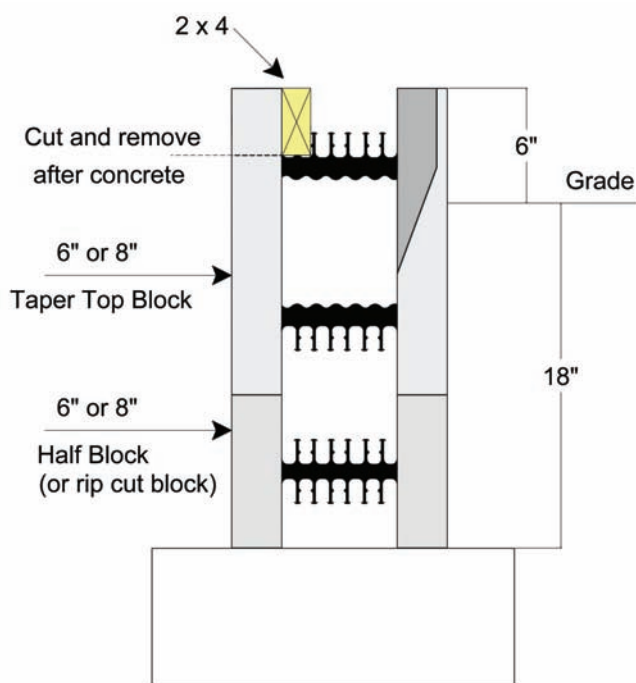

One and one half rows of Fox Blocks

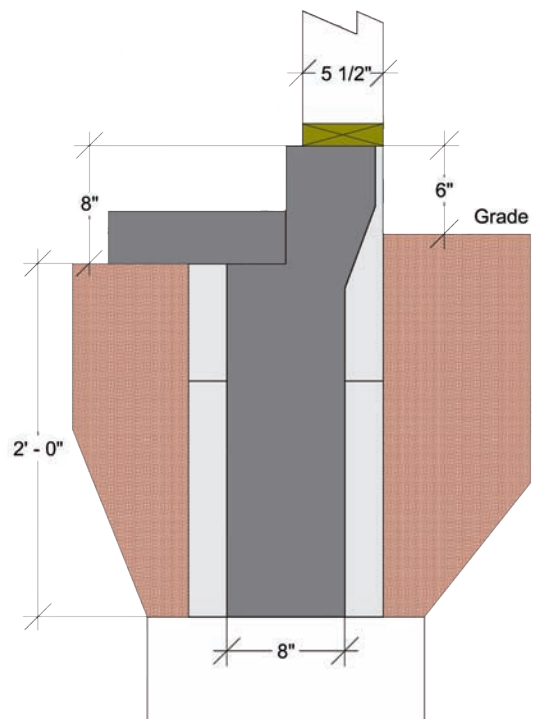

Using Curb Block allows you to lower slab to give a curb that does not require any finish. Taper is field cut into the top outside edge

# ICF BRACING/SCAFFOLD

When building walls over three courses tall, Fox Blocks recommends the use of ICF Bracing/Scaffolding.



The above photo shows two racks of 24 bracing sets for a total of 48 sets. At six foot on center, this would be enough for 288 lineal feet of ICF wall.



## ICF BRACING/SCAFFOLD HAVE THREE MAIN PARTS:

- 1) STIFF BACK WHICH IS ATTACHED TO THE STUDS IN THE WALL**  
Screw to ties in block which are 8" o/c. One screw per block row.
- 2) TURNBUCKLE WHICH ADJUSTS THE WALL.**  
Threaded rod within the turnbuckles tilt wall in or out as you turn it.
- 3) PLANK SUPPORT ARM FOR SCAFFOLD.**  
Will accept two 2 x 10's and toe kick.



Simply stake or screw the turnbuckle feet to the ground or floor

With the proper kits, this type of scaffold can be used for walls up to 24' tall. Contact Fox Blocks for walls over 24' tall. It has become common to see walls 30' to over 60' tall.

FACTS	
10' Brace Set =	75 Lbs
12' Brace Set =	88 Lbs
24 x 10' and rack =	1950 Lbs
24 x 12' and rack =	2250 Lbs
Budget one brace every 6' of wall	
End user provides planks railing & screws	

\* Guard rail posts are also provided for those taller jobs



## WHY USE ICF BRACING/SCAFFOLD

Safe work site and straight walls

The use of a string line will give you straight walls. No one has an eye good enough to straighten walls longer than 20'.



10' or 12' Giraffe Scaffold  
**AVAILABLE THROUGH FOX BLOCKS**  
Racks of 24 sets

# SAMPLE CROSS SECTIONS

Fox Blocks are designed to make walls. Take the time to understand your on site height requirements to ensure accurate material takeoffs.

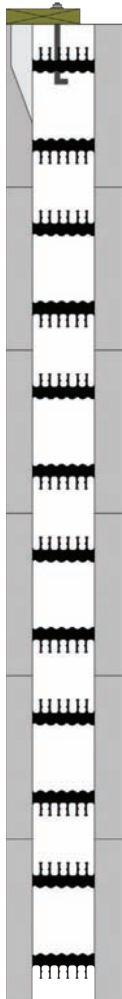

**8' 0" WALL**  
6 - 16" Tall Block

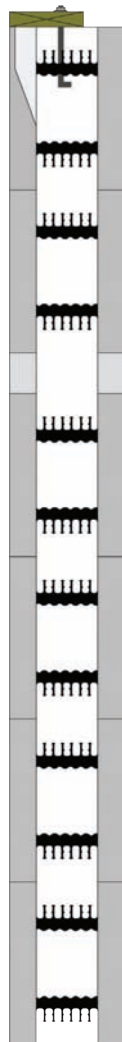

**8' 4" WALL**  
6 - 16" Tall Block  
1 - 4" Tall Block

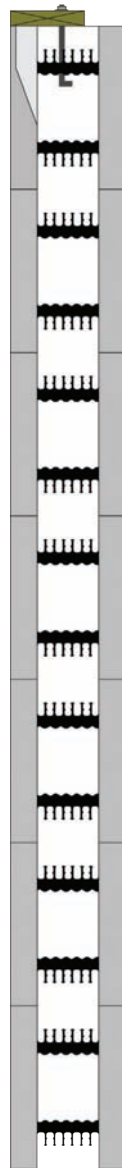

**9' 4" WALL**  
7 - 16" Tall Block

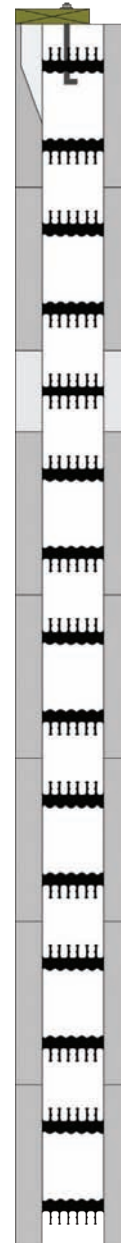

**10' 0" WALL**  
7 - 16" Tall Block  
1 - 8" Tall Half Block

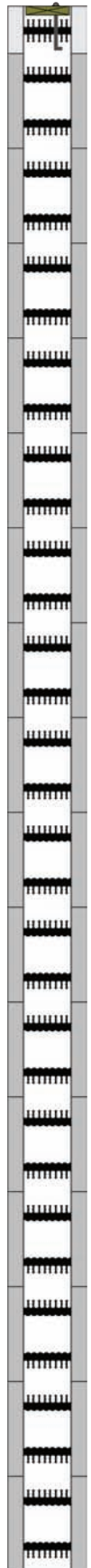

**22' 0" WALL**  
16 - 16" Tall Block  
1 - 8" Tall Half Block

**FOR ALL WALLS:**

- Walls can be 4", 6", 8" 10" or 12" concrete thickness
- Taper Top Block at top of wall is optional
- Bear on slab or footing designed to carry load
- Place proper rebar to meet local building codes or engineering



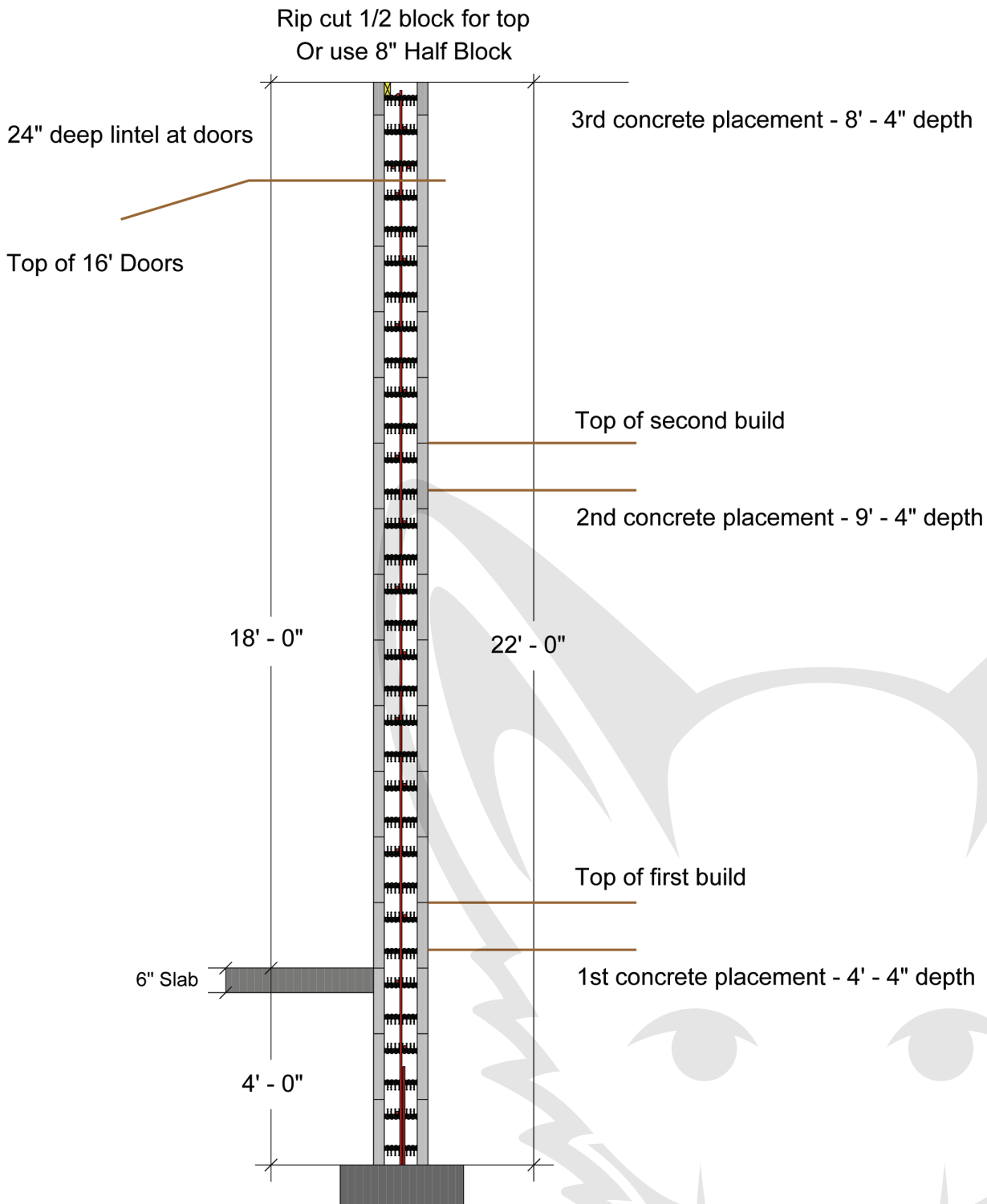

**22'-0" TALL SAMPLE SHOP WALL**

When planning any wall, you want full understanding of the job for accurate takeoffs and low man hour rates. The above job required a 4'-0" stem / frost wall and 16'-0" tall door openings. The contractor used the same cross section to decide the concrete lift heights. The concrete lift heights decide the vertical rebar lengths.



Watch the video of this completed job.

## BASIC ESTIMATING

Fox Blocks offers 3 methods to calculate the block for your project:

- 1) Use the basic math below to quickly calculate your estimate.
- 2) Go to the website [www.foxblocks.com](http://www.foxblocks.com) and use the Project Estimator.
- 3) Go to the website [www.foxblocks.com](http://www.foxblocks.com) and download the stand alone Project Estimator Pro, which includes most aspects of an ICF build.

### ESTIMATING QUANTITIES OF FOX BLOCK FOR YOUR PROJECT USING BASIC MATH:

#### STEP ONE - COLLECT DATA:

Size of block needed (4", 6", 8" or 12") = **A** \_\_\_\_\_  
 Add up the total linear footage of the job = **B** \_\_\_\_\_  
 The number of courses (rows) required:  
 (Wall height in inches / 16" or use chart) = **C** \_\_\_\_\_  
 Number of 90° turns for job = **D** \_\_\_\_\_  
 Inside 90° turns = **E** \_\_\_\_\_ Outside 90° turns = **F** \_\_\_\_\_  
 Number of turns for job other than 90° = **G** \_\_\_\_\_  
 Number of T-Block locations = **H** \_\_\_\_\_  
 Square footage of openings = **I** \_\_\_\_\_

Wall Height options:					
ACTUAL	DECIMAL	INCHES	ROWS	4" ext	Half Block
2'-8"	2.67	32	2	0	0
3'-4"	3.00	36	2	1	0
4'-0"	4.00	48	3	0	0
4'-4"	4.33	52	3	1	0
5'-4"	5.33	64	4	0	0
5'-8"	5.67	68	4	1	0
6'-8"	6.67	80	5	0	0
7'-0"	7.00	84	5	1	0
7'-4"	6.67	80	5	0	1
8'-0"	8.00	96	6	0	0
8'-4"	8.33	100	6	1	0
8'-8"	8.00	96	6	0	1
9'-4"	9.333	112	7	0	0
9'-8"	9.667	116	7	1	0
10'-0"	9.333	112	7	0	1
10'-4"	9.667	116	7	1	1
10'-8"	10.667	128	8	0	0
11'-0"	11.000	132	8	1	0
11'-4"	10.667	128	8	0	1
11'-8"	11.000	132	8	1	1
12'-0"	12.000	144	9	0	0
12'-4"	12.333	148	9	1	0
12'-8"	12.000	144	9	0	1
13'-0"	12.333	148	9	1	1
13'-4"	13.333	160	10	0	0
13'-8"	13.667	164	10	1	0
14'-0"	13.333	160	10	0	1
14'-4"	13.667	164	10	1	1
14'-8"	14.667	176	11	0	0

#### STEP TWO - CALCULATE BLOCK REQUIREMENTS:

90° block needed: **D x C** (Total number of 90° turns times the number of rows high)  
 45° block needed: **G x C** (Total number of 45° turns times the number of rows high)  
 T Block needed: **H x C** (Total number of T Block locations times the number of rows high)  
 Straight Block needed: (Use chart and calculations below)

Fox 90° Corner Size Chart		
Block Size	Length in feet	
	Inside	Outside
4"	① = 3.5	② = 5.0
6"	① = 3.5	② = 5.3
8"	① = 3.6	② = 5.6
10"	① = 3.6	② = 5.6
12"	① = 3.7	② = 6.3

Fox 45° Corner Size Chart		
Block Size	Length in feet	
	Inside	Outside
4"	③ = 3.5	③ = 3.5
6"	③ = 3.5	③ = 3.5
8"	③ = 3.5	③ = 3.5
10"	③ = 0.0	③ = 0.0
12"	③ = 0.0	③ = 0.0

T-Block Size Chart		
Block Size	Length in feet	
	Inside	Outside
4"	—	④ = 0.0
6"	—	④ = 3.5
8"	—	④ = 3.5
10"	—	④ = 0.0
12"	—	④ = 0.0

$(E \times j) + (F \times k) + (G \times l) + (H \times m) = \mathbf{J}$  \_\_\_\_\_ (Linear feet of wall taken up by corners and T Block)  
 $B - J = \mathbf{K}$  \_\_\_\_\_ (Total linear feet of wall taken up by straight block)  
 $I / 5.33 = \mathbf{L}$  \_\_\_\_\_ (Number of block taken up by openings. 5.33 is sq. ft. per block)  
 $(K \times C) - L =$  Total Straight block needed for job not including waste factor. (Add 3% for waste)

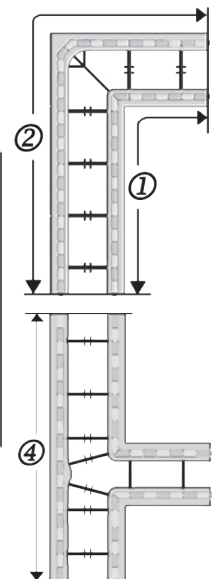

See next page for more calculations.

**STEP THREE - OTHER TYPES OF BLOCK:**

**Taper Block needed (only available in 6" & 8"):**

Linear feet of taper block need / 4 (4 = length of one corbel block)  
Remove this number from the straight block count

**Corbel Block needed (only available in 6" & 8"):**

Linear feet of corbel block need / 4 (4 = length of one corbel block)  
Remove this number from the straight block count

**Radius block needed (only available in 6"):**

Linear feet of radius block need / 1.33 (1.33 = length of one corbel block)  
Remove one straight block for every three radius block needed

**Curb Block needed (only available in 8" at this time):**

Straights: (Total linear footage of wall - total linear footage taken up by 90° corners)/4 = number of straight curb blocks  
Remove this number from the straight block count  
Corners: Number of 90° turns = Number of 90° corner blocks  
Remove this number from the 90° corner block count

**1/2 block needed (only available in straight and 90° corner blocks):**

Same formulas as straight and 90° corner blocks.

**Energy Sticks needed (will fit all block):**

Total number of block for job x 3.

**STEP FOUR - CALCULATE CONCRETE:**

Fox blocks volume is exactly 4", 6", 8", 10" or 12" so calculate as you would other regular concrete formwork.

The following chart will give volumes per block:

Concrete Volumes											
Cubic Yards						Cubic Meters					
Block Type	Size					Block Type	Size				
	4"	6"	8"	10"	12"		4"	6"	8"	10"	12"
Straight	0.066	0.099	0.132	0.165	0.198	Straight	0.05	0.076	0.101	0.126	0.151
90 corner	0.07	0.105	0.145	0.181	0.212	90 corner	0.054	0.08	0.111	0.138	0.162
45 corner	0.066	0.082	0.117	NA	NA	45 corner	0.05	0.063	0.089	NA	NA
Corbel Block	NA	0.129	0.162	NA	NA	Corbel Block	NA	0.099	0.124	NA	NA
Taper Block	NA	0.111	0.144	NA	NA	Taper Block	NA	0.085	0.11	NA	NA
T Block short	NA	0.105	0.141	NA	NA	T Block short	NA	0.08	0.108	NA	NA
T Block long	NA	0.121	0.152	NA	NA	T Block long	NA	0.093	0.116	NA	NA
Radius Block	NA	0.033	NA	NA	NA	Radius Block	NA	0.025	NA	NA	NA

**STEP FIVE - MISC:**

**Fox Blocks HV Clips:** One box for every 150 block ordered (One box = 250 Fox Block HV Clips)

**Bracing:** Linear feet of wall / 6'

**Fox Buck:** Lineal footage of openings / 4' and round up-

**Rebar:** (Number of rows needed x Linear feet of wall) + (Linear feet of wall / spacing needed)  
Add 10% to horizontal rebar total for lap splices.

# MAN HOUR RATES

- To budget a job properly for efficiency in crew size
- To budget a job properly to land job
- To be profitable

Man Hour Rates (MHR) have been around for decades. Most contractors document their production rates without realizing that time / square footage built will give them a man hour rate similar to those found in most cost estimating programs, such as RS Means. For most Insulated Concrete Forms (ICF), this has become a common practice. Over 20 years of history have established accurate numbers to budget future jobs.

	MHR	JOB TYPE	
<b>1</b>	.055 or less	Very efficient crew building a simple job with less than six corners, less than four openings and few or no embeds.	<p><b>NOTES:</b></p> <p>Size of job is not as big of a factor as you would think. The only time the size of job is really a factor is when the job is so large that the crew can gain speed while building, which lowers the MHR. This will usually be on jobs over 20,000 square feet using the same crew throughout.</p> <p><b>WAYS TO LOWER YOUR MHR:</b></p> <ol style="list-style-type: none"> <li>1. Pre-Plan Job</li> <li>2. Proper Size Crew for Job</li> <li>3. Stage Materials Close to Job</li> <li>4. Use Proper Scaffold/Bracing</li> <li>5. Pre-Build Opening Bucks</li> <li>6. Proper Rebar Placement</li> <li>7. Fox Training for Crew</li> </ol>
<b>2</b>	.06 .065 .07	Average job with less than eight corners, less than eight openings and less than eight embeds.	
<b>3</b>	.075 .08 .085	Most common MHR for new crews on moderate or large jobs. This will cover complex residential jobs with 12 or less corners. This MHR area will also work with large commercial jobs with basic 16" o/c rebar and few openings.	
<b>4</b>	.085 .095 .10 .105	Very complex residential with 12 or more corners and many openings and embeds. Also includes commercial jobs with many openings and embeds or more than 3 levels in height.	
<b>5</b>	.11 and over	ICF jobs with at least three of the following: More than 8 short corners (30" or less), high seismic rebar design, more than 20 openings, many embeds, extreme weather, using the wrong scaffold for wall height, over 3 levels in height.	

Square foot of Job (SFJ) = Length \* Height (of Fox walls being built)

**SFJ \* MHR = MAN HOURS TO BUILD JOB**

Example: Job has 180 Lineal feet (LF) of wall that is 12' tall.  $180 * 12 = 2160$  square feet (SF)  
 Job has 6 corners with 6 openings and basic 16" o/c rebar design. Crew has a bit of experience and ICF scaffold is used. We recommend aiming for a .075 MHR but use **.085** MHR as a budget number. With experience you will become more efficient, landing more work with more profit.  
 $2160 * .085 = 183.6$  Total Man Hours (TMH) for job  
 $183.6 \text{ TMH} / 6 \text{ man crew} = 30.6$  Total Crew Hours (TCH)

*These numbers are estimates only. Many factors will effect the outcome of a job which needs to be taken into account. Please document all work and reflect back to your own crews history when completing budgets for upcoming work. We would like to thank contractors for sharing past history allowing us to build accuracy into this document.*

# THE FOX BLOCKS ESTIMATOR PRO 4

## TAB 1: WALL DATA

Fill in the basics: height, length, width, and whatever else your job will need.

## TAB 2: OPENINGS

As an option, you can input openings one at a time or in groups. The data can then be transferred to the wall data page.

## TAB 3: FOX PARTS

Gives you the Fox Blocks parts needed for this page.

## TAB 4: WORKSHEET DATA

A printable page showing all numbers you have entered, all product required, as well as additional information like bracing requirements.

## TAB 5: WORKBOOK SUMMARY

This is the pricing page which allows you to input and save your price lists and gives totals for entire project.

## TAB 6: REBAR CALCULATOR

Allows you to calculate total footage of rebar for your job including footings and slabs.

## TAB 7: CONCRETE CALCULATOR

Allows you to calculate total concrete needed for your job including footings, piles and slabs.

## TAB 8: 1440 TILT CALCULATOR

Calculates parts needed for tilt up jobs using the Fox Blocks 1440 product.

## TAB 9: MAN HOURS

Import worksheet numbers and easily calculate cost of job.

## FILE MENU

Save your estimates as .fox files and choose from a variety of printouts

## JOB NAME & INFORMATION

Fill out the job name and client information. There is no limit to the number of levels in your project.

## OPTIONAL RADIUS BLOCK AND R9 ENERGY STICKS

## BLOCK INFORMATION

Only fill out what you need for your job. You can even add a few spare blocks to the quote for insurance.

Go to <http://www.foxblocks.com/project-estimator/> to download the full Estimator PRO 4 for Windows or MAC.



# TECHNICAL PERFORMANCE DATA

## Fox Block ICF Wall System

### CONCRETE WALL CONSTRUCTION (4", 6", 8", 10" & 12" Reinforced Structural Concrete Core)



Design criteria for the structural concrete wall system	ACI 318 design standards for straight wall concrete construction
Recommended concrete consolidation	Reference the Fox Block Installation Manual, ACI 309
Fox Blocks Installation Manual	Second Edition (2012)
Prescriptive Design of Exterior Concrete Walls	PCA 100-2012, IRC R404.1, R611, ACI 332
Average weight of the reinforced structural concrete	150 lbs. / cu. ft. (including steel reinforcement)
Thermal Mass (form & 4" reinforced concrete core)	50 lbs. / sq. ft.
Thermal Mass (form & 6" reinforced concrete core)	75 lbs. / sq. ft.
Thermal Mass (form & 8" reinforced concrete core)	100 lbs. / sq. ft.
Thermal Mass (form & 10" reinforced concrete core)	125 lbs. / sq. ft.
Thermal Mass (form & 12" reinforced concrete core)	150 lbs. / sq. ft.
Recommended concrete core compressive strength	Minimum 3000 psi for the walls (minimum 2500 psi for footings)
Recommended concrete core slump flow for pump mix design	4" ICF - 6" to 7"; 6" ICF - 5.5" to 6.5"; 8", 10" or 12" ICF - 5" to 6"
Recommended aggregate size for the concrete mix design	4" ICF - 3/8" max.; 6" ICF 3/8" to 1/2" max; 8", 10" & 12" ICF - 1/2" to 3/4" max.

### PRODUCT PERFORMANCE & THIRD PARTY TESTING

#### Expanded Polystyrene (EPS) Testing:

EPS Foam Resin	Modified low pentane, B/C bead size (resin is self-extinguishing)
EPS Average Manufacturing Density / Type	1.5 lbs. / cu. ft. (Type II, Rigid Cellular EPS Foam Plastic)
ASTM C578, EPS Thermal Insulation Properties	<b>Fire Safety &amp; Testing:</b> Surface Burning Characteristics of Foam Plastics, ASTM E84 & ANSI / UL 723
CAN / ULC S701, EPS Thermal Insulation Properties	

#### Plastic Tie Strength Testing:

Fastener Withdrawal, ASTM D1761
Fastener Lateral (Shear), ASTM D1761
Tie Tensile and Shear, ASTM D638 and D732

#### Performance Testing:

Sound Transmission Class (STC), ASTM E90, STC 45-50+
--

#### Environmental, Safety & Energy Performance:

No HCFC's or CFC's emitted during the manufacturing process
No toxins or formaldehydes produced
Plastic ties are recycled and the EPS Foam forms are recyclable

#### Products & Energy Efficient Accessories:

Energy Stick	R-8 / Stick
--------------	-------------

#### Energy Efficiency Data & Performance:

Thickness of the EPS	2.625" / wall panel (5.25" total EPS thickness)
EPS Steady State R-Value (thermal resistance of the material)	R - 4.17 (@ 70 degrees Fahrenheit)
CTL Group Thermal Resistance R-Value Calculation Report	R - 23+ / Block (calculated in accordance with ASHRAE 90.1)
EPS K-Factor (thermal conductivity of the material)	K - 0.24 / inch (@ 70 degrees Fahrenheit)
Air Leakage (infiltration rate) ASTM E283	0.002 cfm / ft <sup>2</sup>
ORNL Thermal Mass Calculator Dynamic R-Value Equivalent	Greater than R - 32

#### Storm Safety:

Wind Capacity	Fox Blocks ICF Walls can be designed to meet code requirements
Seismic Zones	Fox Blocks ICF Walls can be designed to meet code requirements

#### Fire Safety & Testing:

Surface Burning Characteristics of Foam Plastics, ASTM E84 & ANSI / UL 723	
Flame spread from the EPS Foam	less than 25
Smoke Development of the EPS Foam	less than 450
Surface Burning Characteristics of Foam Plastics, CAN / ULC S102	
Fire Burning Characteristics of Plastic Ties	
ASTM D1929, Flash Ignition Temp	400 (C) 752 (F)
ASTM D1929, Spontaneous Ignition Temp	380 (C) 716 (F)
ASTM D635, Burn Rate	Meets Class CC1
Fire Resistance Rating, ASTM E119 (equivalent Standard Test Methods)	
4" Concrete Core	2 hrs.
6" Concrete Core	3 hrs.
8", 10" or 12" Concrete Core	4 hrs.
Fire Endurance Test of Building Construction Materials, CAN / ULC S101	
Room Fire Test, UL 1715 (with 1/2" gypsum board)	
<i>MSDS sheets available at <a href="http://www.foxblocks.com">www.foxblocks.com</a></i>	

#### BUILDING CODE REFERENCES

IRR-1010	Miami-Dade County Product Division NOA # 13-0124.01
CCMC - 13472-R	Florida Product Approval - FL7497-R1 City of New York - MEA 201-08-M City of Los Angeles - RR25689 State of Wisconsin - 201403-1
ASTM E2634	
CAN/ULC S717.1	

# FOX BLOCKS BY THE NUMBERS

	Item Number	Block Type	Total Width	Total Height	Outside dimensions Length/Surface area		Inside dimensions Length/Surface area		Concrete Volume yd	Concrete Volume M	Bundle Quantity		Actual Bundle Size Length/Width/Height		Weight Bundle/Piece	
4	FOX-S400	Straight Block	9.25	16	48	5.33	48	5.33	0.066	0.05	12	38	49	49	84	7
	FOX-S400HB	Straight 1/2 Block	9.25	8	48	2.67	48	2.67	0.033	0.025	24	38	49	49	84	7
	FOX-EC490	90° Corner Block (38 x 22)	9.25	16	60	6.67	41.5	4.61	0.07	0.0535	12	46	47	49	95	8
	FOX-EC490HB	90° Corner 1/2 Block	9.25	8	60	3.34	41.5	2.31	0.348	0.027	24	46	47	49	95	8
	FOX-BUCK4	Fox Buck	9.25	2	48	3.08	n/a	n/a	n/a	n/a	12	48	9.25	27.25	29	2.65
	FOX-EC445	45° Corner Block (34 x 18)	9.25	16	52	5.78	44	3.57	0.066	0.05	9	40	50	49	58	6.4
6	FOX-S600	Straight Block	11.25	16	48	5.33	48	5.33	0.099	0.0757	12	45.5	49	49	90	7.5
	FOX-S600HB	Straight 1/2 Block	11.25	8	48	2.67	48	2.67	0.0494	0.0378	24	45.5	49	49	90	3.75
	FOX-EC690	90° Corner Block (40 x 24)	11.25	16	64	7.11	41.5	4.6	0.105	0.08	12	53	49	49	102	8.47
	FOX-EC690HB	90° Corner 1/2 Block	11.25	8	64	3.56	41.5	2.31	0.0543	0.0415	24	53	49	49	102	8.47
	FOX-C645	45° Corner Block (26 x 18)	11.25	16	44	4.89	34.875	3.85	0.082	0.063	9	40	49	49	58	6.4
	FOX-TB600	T-Block Short	11.25	16	44	4.89	4.375	n/a	0.105	0.08	6 (3+3)	40.25	43.25	49	56	9.4
		T-Block Long	11.25	16	44	4.89	12.375	n/a	0.121	0.0925					56	9.4
	FOX-BL600	Corbel Ledge	11.25	16	48	5.33	n/a	n/a	0.129	0.099	9	45.25	45.5	49	80	8.8
	FOX-TT600	Taper Top	11.25	16	48	5.33	n/a	n/a	0.111	0.085	12	45.25	49	49	56	7.3
	FOX-RB60_	Radius	11.25	16	16	1.77	n/a	n/a	0.033	0.025	27	39	49	49	68	2.5
FOX-BUCK6	Fox Buck	11.25	2	48	3.75	n/a	n/a	n/a	n/a	12	48	11.5	27.25	33	2.75	
FOX-Strip 6	Stirups for corbel block	n/a	n/a	n/a	n/a	n/a	n/a	n/a	n/a	40	13	11	9	25	0.65	
8	FOX-S800	Straight Block	13.25	16	48	5.33	48	5.33	0.132	0.101	12	54.5	49	49	90	7.5
	FOX-S800HB	Straight 1/2 Block	13.25	8	48	2.67	48	2.67	0.065	0.05	24	54.5	49	49	90	7.5
	FOX-EC890	90° Corner Block (42 x 26)	13.25	16	68	7.56	41.5	4.6	0.153	0.117	6	41	44	49	60	9.83
	FOX-EC890HB	90° Corner 1/2 Block	13.25	8	68	3.78	41.5	2.3	0.076	0.058	12	41	44	49	60	9.83
	FOX-C845	45° Corner Block (28 x 20)	13.25	16	48	5.33	37	4.11	0.117	0.089	9	53	47	49	58	6.4
	FOX-TB800	T-Block Short	13.25	16	44	4.89	4.75	n/a	0.141	0.108	6 (3+3)	40.25	43.25	49	56	9.4
		T-Block Long	13.25	16	44	4.89	8.75	n/a	0.152	0.116					56	9.4
	FOX-BL800	Corbel Ledge	13.25	16	48	5.33	n/a	n/a	0.162	0.124	9	53.25	49.5	49	80	8.9
	FOX-TT800	Taper Top	13.25	16	48	5.33	n/a	n/a	0.144	0.11	12	54.5	49.25	49	87	7.3
	FOX-S800CB	Curb Block - Straight	13.25	16	48	5.33	n/a	n/a	0.132	0.101	12	54.5	49	49	91.2	7.6
	FOX-EC890CB	Curb Block - 90° Corner	13.25	16	68	7.56	41.5	4.6	0.145	0.111	6	41	44	49	60	9.92
	FOX-BUCK8	Fox Buck	13.25	2	48	4.42	n/a	n/a	n/a	n/a	12	48	13.5	27.25	38	3.2
FOX-Strip 8	Stirups for corbel block	n/a	n/a	n/a	n/a	n/a	n/a	n/a	n/a	40	13.5	11.5	9.5	28	0.7	
10	FOX-S1000	Straight Block	15.25	16	48	5.33	48	5.33	0.165	0.126	9	46	49	49	74	7.86
	FOX-S1000HB	Straight 1/2 Block	15.25	8	48	2.67	48	2.67	0.0823	0.063	18	46	49	49	74	7.86
	FOX-EC1090	90° Corner Block (42 x 26)	15.25	16	76	7.56	41.5	4.6	0.181	0.138	6	41	44	49	68	10.5
	FOX-EC1090HB	90° Corner 1/2 Block	15.25	8	76	3.78	41.5	2.3	0.092	0.07	12	41	44	49	68	10.5
	FOX-BUCK10	Fox Buck	15.25	2	48	5.08	n/a	n/a	n/a	n/a	12	48	15.5	27.25	42	3.4
12	FOX-S1200	Straight Block	17.25	16	48	5.33	48	5.33	0.198	0.151	9	54	49	49	74	8.22
	FOX-S1200HB	Straight 1/2 Block	17.25	8	48	2.67	48	2.67	0.099	0.076	18	54	49	49	74	4.12
	FOX-EC1290	90° Corner Block (46 x 30)	17.25	16	76	8.42	41.5	4.6	0.212	0.162	6	46.5	49.25	49	68	11.17
	FOX-EC1290HB	90° Corner 1/2 Block	17.25	8	76	4.21	20.75	2.3	0.106	0.081	12	46.5	49.25	49	68	5.75
	FOX-BUCK12	Fox Buck	17.25	2	48	5.75	n/a	n/a	n/a	n/a	12	48	17.25	27.25	46	3.7

Please go to:  
**WWW.FOXBLOCKS.COM**

**WHERE YOU WILL FIND:**

- Regional Manager Contact Information
- Local Dealer Contact Information
- Downloadable Technical Files
- Estimating Software
- On-Site Movies
- Photos & More



**LIKE US**  
f /FoxBlocks

**FOLLOW US**  
@foxblocksicf

**CHANNEL**  
/foxblocksairlite

**HEAD OFFICE:**  
6110 Abbott Drive | Omaha, NE 68110 | 1-877-369-2562

Manufactured in USA: AK, AL, AZ, CA, CO, FL, ID(2),  
IN, MA, MI, MN, NC, NE, PA, TX  
Manufactured in Canada: QC, MB, AB, NB

A PRODUCT OF:



MAKING YOUR SUCCESS OUR DESTINATION

